

Textile study courses – evaluation of student performance over one complete decade

Boris Mahltig

Hochschule Niederrhein, Faculty of Textile and Clothing Technology, Mönchengladbach, Germany

*Corresponding author E-mail address: boris.mahltig@hs-niederrhein.de

INFO

CDAPT, ISSN 2701-939X
Peer reviewed article
2022, Vol. 3, No. 2, pp. 212-225
DOI 10.25367/cdatp.2022.3.p212-225
Received: 25 August 2022
Accepted: 18 September 2022
Available online: 13 November 2022

ABSTRACT

The success of students and their performance are influenced by manifold parameters. The current study focusses especially on the correlation between study duration and the student performance. Investigated are the numbers of two textile related courses (bachelor and master) over the complete time frame of one decade. Data of more than 800 students are considered. Data evaluation is done with the final marks of the students and by using a calculated value – the student performance index PI. Especially discussed is the behavior of long-time students needing more than the double of the regular study duration. In this study only results of students are discussed which successfully finished the study course with a degree. Students leaving without a degree are not considered. For the bachelor course a correlation of their final grades with larger study duration can be determined. In contrast, for the master course nearly no influence of the study duration on the student performance is determined. A possible explanation for these different results can be discussed with the different reasons for longer study duration. For master course it is obviously the situation that the studying is combined with part-time or even full-time jobs. This combination of job and study course leads even for excellent students to prolonged study duration. With this background, for future developments a special designed part time master study course should be developed and offered for students who like the combination of a job carrier with gaining simultaneously a master degree.

Keywords

Academic performance,
Study duration,
Textile education,
International study courses,
Student performance index

© 2022 The authors. Published by CDAPT.

This is an open access article under the CC BY-NC-ND license <https://creativecommons.org/licenses/> peer-review under responsibility of the scientific committee of the CDAPT.

© 2022 CDAPT. All rights reserved.

1 Introduction

The evaluation of the academic performance of students is the topic of several reports [1-3]. Various parameters are useful to determine this academic student performance. Such parameters are the number of students finally receive the degree, the number of courses passed or the number of credit points gained in a certain period of study time. Another parameter is the mark of the final degree. Earlier investigations evaluate the performance as function of different influences [1-6]. Additional to the general performance, also the performance in single exams are topic of investigation. Here for example chemistry exams are of interest, because in many study courses often chemistry is a significant problem for students in science or technology [7,8]. An interesting evaluation is also done by Darwish et al. [6]. These authors evaluate the influence of the family status on the academic performance [6]. An issue which is up to now less investigated is the influence of the study duration on the academic performance. In this field, a Croatian group reported on the positive influence of an extended study duration from five years to six years [9]. However, this Croatian study is related to the regular study duration and not on the individual study duration, which can be longer.

With this background, the actual study supports a view on the final mark as function of the individual study duration independently from the regular study duration. For this, two study courses related to textile technology at a German university of applied sciences are evaluated. It has to be stated that the German university system promotes in a certain way a longer study duration, so it is an ideal field for evaluating the academic performance as function of study duration.

The study situation at German universities is especially in two points quite different compared to the university systems in many other countries. First, the student fee which has to be paid each semester is quite low for public universities in Germany. Private universities are still a minority in Germany. Second, there are only small restrictions limiting the study duration, so there are only limited mechanisms to force a student to finish the study degree in a certain period of time. There is often only mentioned a term "regular study time", which is practically the minimum number of semesters necessary to finish the degree according to the official study plan. However, there is no regulation that the students have to finish their degree in the frame of this regular study time. For this reason, a significant number of students complete their degree with extended duration. This statement is especially valid for master study courses with a short regular study duration of three or four semesters, where several master students are already working part time in a company or in a research institute.

In this situation of a broad variation in study duration, the question arises if there is a correlation between study duration and academic performance of the students. For this, student numbers from two study courses over a long time period with more than 10 years are evaluated. The first is a bachelor course "Textile and Clothing Management / TCM" and the second is a master course "Management of Textile Trade and Technology / MTTT". Both courses are given in English language. These study courses started together in the year 2010 with a new study regulation. The students in the bachelor course are allowed to start according to these regulations latest till 2016 and have to finish latest the degree till end of August 2022. The last 2.5 years are affected by the Covid-19 pandemic situation. Master students were allowed to start till spring 2017 and they have to finish latest till end of February 2020. These time scales are illustrated in Figure 1. In contrast to the bachelor course, no influence of the Covid-19 pandemic can be expected, because governmental restrictions due to Covid-19 started in Germany in March 2020 and the master course is finished till February 28, 2020. It can be even stated that this last week in February 2020 was the last regular week at German universities without any pandemic related restrictions. By view on this time scale, it is clear that a bachelor student who started in 2010 is allowed to study longest 12 years until getting the bachelor degree in the frame of this study regulation. 12 years are more than three times longer compared to the regular study duration of 3.5 years. In comparison a bachelor student who started in the year 2016 has only 6 years maximum study duration. For master students starting in 2010 the time to finalization of the degree is shorter with only 10 years. However, these 10 years are even more than six times longer compared to the regular study duration of 1.5 years for this master program. In comparison, a master student who started in spring 2017 has only three years maximum duration.

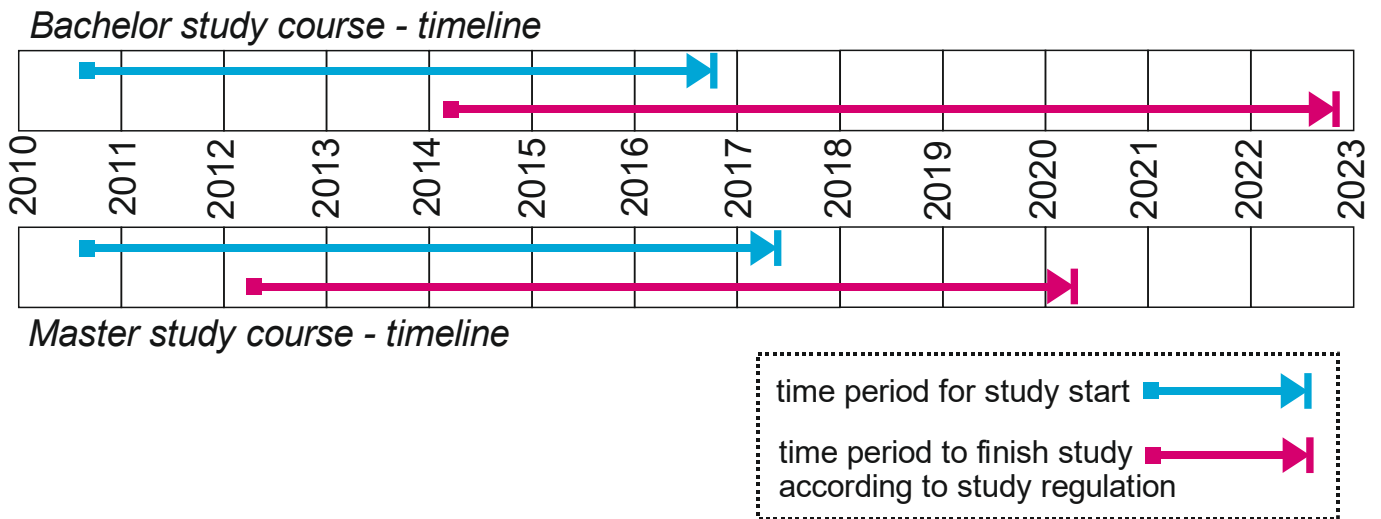

Fig. 1 Timelines for the bachelor and master courses. The periods where start and finishing of the study courses are possible are indicated by colored arrows.

2 Background and framework of study courses

In current evaluation two different study courses are considered – a bachelor course and a master course. The full name of this bachelor course is “Textile and Clothing Management” (TCM) and it contains study elements in the field of science, textile engineering, clothing and economics. Altogether, eight elective courses are offered, covering topics in different fields, as e.g. marketing, design, textile technology or clothing. The finally achieved academic degree is Bachelor of Science. It is completely given in English language. For this, the bachelor course is especially attractive also for international students. However, only 10% of study beginners from abroad are allowed for the start as 1st semester students. This restriction is given by the government and not by university. The full name of the master course is “Management of Textile Trade and Technology” (MTTT). Here the students can choose between two different study directions “Trade and Retail” (TR) or “Technical Textiles” (TT). The further presented data do not distinguish between both study directions – only the complete course MTTT is evaluated. The finally achieved academic degree is Master of Science. Also, this master course is given completely in English language. However, in contrast to the bachelor course there is no limiting regulation regarding to the number of allowed international students. For this, in this master course international students are the majority.

3 Evaluation of academic performance

The academic performance of each student is definitely determined by the final mark gained after bachelor or master degree. In the current study this performance is evaluated as function of the study duration. The possible marks are in the range of 1.0 (best result) to 4.0 (lowest result). From these values the student performance index PI can be calculated as reciprocal value of student mark by using the formula (1). The value m is here the final mark, individual for each student.

$$PI = \frac{1}{m} \quad (1)$$

By using this equation to calculate the PI from the final mark, the PI can be in maximum 1 for a mark 1.0 and in worst case 0.25 for a mark 4.0. With this type of reciprocal evaluation better students are higher evaluated. This student performance index only considers the final mark and is for this quite simple. As second parameter grading the student performance also the study duration can be considered. A student gained an excellent mark in regular study duration has obviously a better performance compared to a student with the same excellent mark reached after extended study duration. To consider both the final mark and the study duration, an advanced study performance index PID can be defined – there D stands for the duration of the individual study time for the student. The PID is calculated according to formula

(2). The individual study duration ST_i in number of semesters is set in correlation to the regular study duration ST_r (for bachelor course TCM $ST_r = 7$ semester; for master course MTTT $ST_r=3$). This regular study duration is given by the official study regulation for each course.

$$PID = \frac{1}{m} * \frac{ST_r}{ST_i} \quad (2)$$

For students who finished the study in the regular duration both indices PI and PID are equal. However, with extended study duration the PID decreases significantly. In the current investigation, it is evaluated how the study duration influences the student performance, so the main parameter for relevant discussion is the PI, because it is independent from the study duration. Using the PID for discussion leads of course to a lower performance value for students with longer study duration. Data evaluation is done by linear regression using the software OriginPro 2020.

4 Data and Evaluation

4.1 Student numbers

The numbers of students of bachelor and master courses are presented together in Figure 2. In the following sub-sections, bachelor and master courses are presented separately. The number of study beginners over the complete time period is presented in Figure 2. The number of beginners is compared with students who finished successfully their degree. In the time period from 2011 to 2016, 652 bachelor students started. Till the year 2022, 544 of these students finished their bachelor degree successfully. For the master course, from 360 student beginners, 335 students gained the master degree till 2020. From these numbers, a ratio of 16.6 % bachelor candidates and 6.9 % master candidates result which do not receive the aimed degree. This loss of students is probable attributed to several reasons. Only few students fail finally during an exam. Beside this, some students changed to other study courses in the same faculty or other faculties. Ten bachelor students do not finish the degree till 2022 and have to change to a new study regulation. Other students stop studying because of different external reasons – economic or family based.

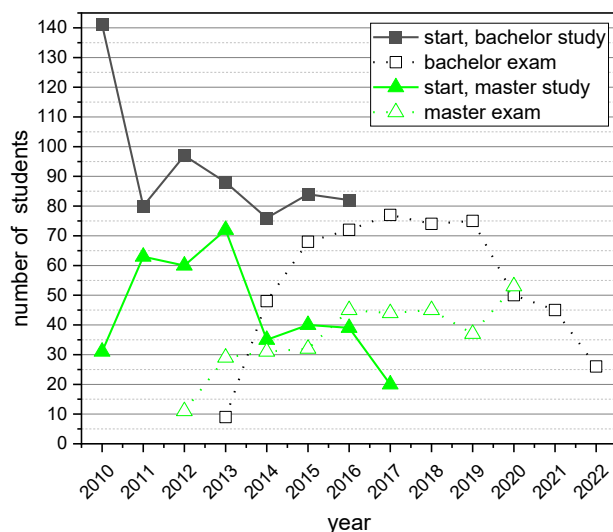

Fig. 2 Number of students starting the study courses and finishing them successfully. The numbers are given according to the year of event. Over the complete period of time, 652 students started in the bachelor course and finally 544 finished it successfully. Further, 360 students started in the master course and finally 335 students finished the master course successfully.

With exception of year 2010, between 75 and 100 students started every year in the bachelor course. The big number of 141 beginners in 2010 can be explained by a restriction for entering other bachelor courses, so students who originally liked to join other bachelor courses joined alternatively this TCM bachelor course. First bachelor students finished the degree in year 2013. From 2015 to 2019, each year

between 68 and 80 students received the bachelor degree. The smaller numbers in bachelor degree in the years 2013 and 2014 are due to a prolonged study duration. According to regular study duration of seven semesters, by view on the big numbers of beginners in year 2010 a big number of bachelor degrees should result in year 2013. However, many students exceed the regular duration and finished instead in following years. From year 2020 on, the number of bachelor degrees decreased again, due to the lack of new beginners in the years after 2016.

For the master course, the number of beginners fluctuates strongly from year to year. This fluctuation is mainly driven by the interest and access of students from abroad. Master beginners with bachelor degree gained at a German university are the minority. One main reason for this issue can be the good job market situation for persons who have got the bachelor degree in Germany. In many cases, joining a company is more attractive compared to proceeding as master student. Same as for the bachelor course, also the first numbers for master degree in the year 2012 are quite small, in comparison with the bigger numbers of beginners in the years 2010 and 2011. In the following years from 2013 to 2019, stable number of master degrees between 30 to 45 each year are reached. Here a continuous output of master degrees is documented. Only in the last year 2020, the biggest number of 55 students gained the master degree. It should be kept in mind that these students finished their degree only in the first two months of 2020. This big number of degrees in 2020 is probable the result of the deadline for the study regulation, because of this the students are forced to finish the master degree.

4.1.1 Bachelor course

The number of students who finished the bachelor degree as function of their study duration is depicted in Figure 3. The regular study duration according to the study plan is seven semesters. However, most students finish their bachelor degree in 8 semesters and the average study duration is with 9.4 semesters even longer. There are also students taking the double or even the triple study duration compared to the regular duration. However, more than 90% of all students get the degree after ten semesters or less.

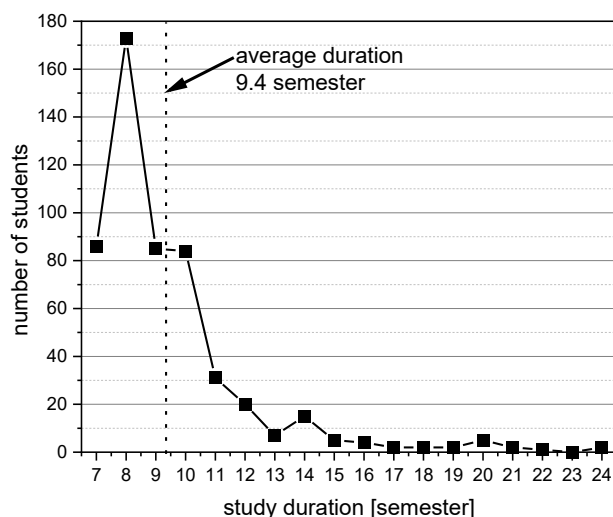

Fig. 3 Number of students who finished successfully the bachelor course as function of their study duration.

To enable a complete view, additionally to the final bachelor degree also the numbers from two lectures are presented more in detail. First, this is the chemistry lecture given in the first and second semester (Figure 4). Its regular exam is offered in June/July each year. A repetition of the exam is possible in the following September and in February of the following year.

Second, numbers for the lecture textile finishing are given (Figure 5). The finishing lectures are given regularly in the third semester. Figure 4 summarizes the number of students who passed the chemistry

exam each year. The number of students is indicated according to the different exam period. Most students passed in the first exam period in June/July each year. Surprising is the small number of students passing chemistry in 2011 and 2012, especially by view on the big number of student beginners in 2010. As discussed in an earlier publication, in year 2011 many students registered themselves for this chemistry exam but do not join the exam event finally in 2011 [8]. Further, from the number of participating students the majority failed this chemistry exam. Mainly two explanations for this issue are reported – the new study regulation and the change of the responsible lecturers in year 2011.

Nevertheless, in the following years from 2013 to 2017 regularly big numbers of students passed the chemistry exam. According to study regulation, the year 2017 is the last regular year to pass the chemistry exam. However, in the following years till 2020 the chemistry exam is offered and a significant number of students with long study duration were able to finish this exam successfully.

In the year 2020 the written chemistry exam was modified, because of the Covid-19 situation [8]. This modification helped probably few remaining students to pass the chemistry exam. It should be further remarked that the number of students passed chemistry exam is only 499 in total and for this smaller compared to the total number of students gained finally the bachelor degree. This difference of 45 students can be explained easily by the transfer of exams. Students who studied earlier at another university and passed there the chemistry exam get a transfer and do not have to repeat the chemistry exam.

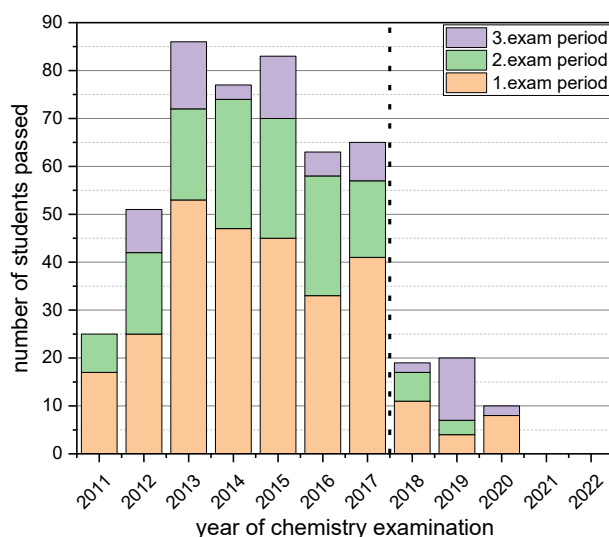

Fig. 4 Number of students who passed the chemistry exam per year time period with the three possible examination events. The dotted line indicates the last examination year according to the regular study duration. Totally, 499 students passed this chemistry examination.

The student numbers for the finishing lecture are presented in Figure 5. The maximum of students passing the finishing exam is reached in the years 2014 and 2015, this is quite late in respect to the big number of student beginners in year 2010. Regarding this big number, there should be the maximum for passed finishing exams earlier in year 2012. Here a clear delay in exam participation can be stated [10]. This delay is also reflected by the significant number of students who passed the finishing lecture in the year 2019 or the following years. Due to the strong relation of the contents of the lectures chemistry and finishing, several students like to start with the finishing exam after they passed the chemistry exam. By this, also the delay with the finishing exams could be explained.

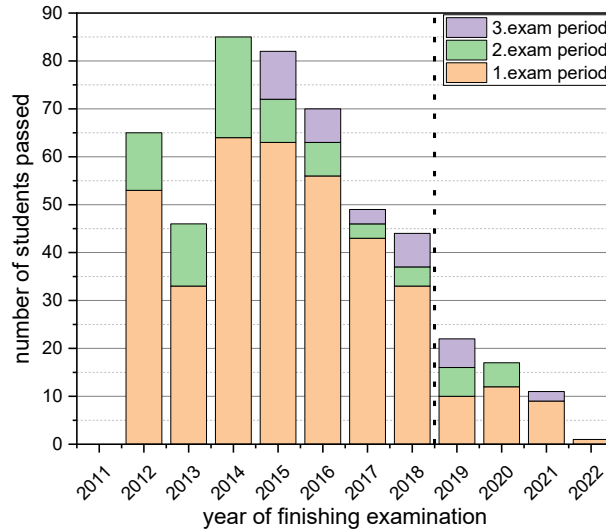

Fig. 5 Number of students who passed the finishing exam per year time period with the three possible examination events. The dotted line indicates the last examination year according to the regular study duration. Totally, 492 students passed this finishing examination.

The annual values of average study duration and average final mark are presented in Figure 6. By view on this graph, there is no clear trend for the average mark over the years. In comparison, the average study duration increases significantly over the years, because in the beginning period of the years 2013 and 2014 there were no long-time students. The strong increase in study duration in the year 2020 is understandable because from 2017 on no new students entered this bachelor course. From the year 2020 to 2022, only long-term students finished their bachelor degree in this study course.

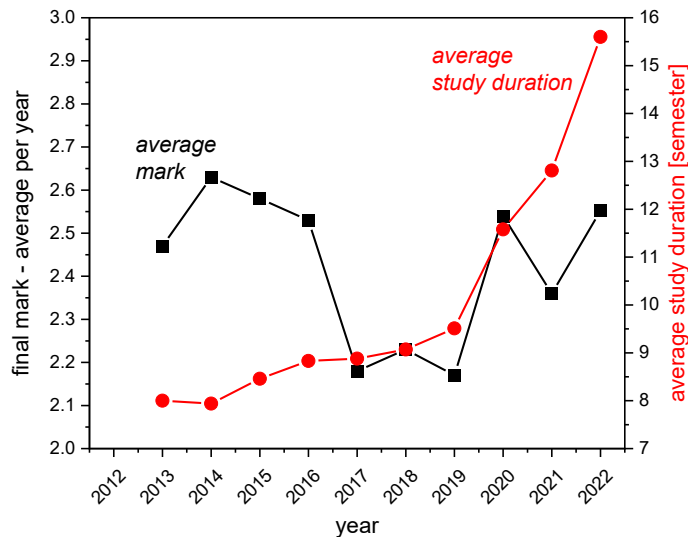

Fig. 6 Average value of bachelor degree and average study duration for all students who finished the bachelor degree in the same year.

4.1.2 Master course

For the complete time period, a broad range in study duration is exhibited by the master students (Figure 7). There are master students who finished their master degree in the regular duration of three semesters. Most master students finished the master degree after four semesters. However, there are also master students with extended study duration up to 17 semesters. The average study duration is

6.9 semesters and by this around twice the regular study duration. There are several reasons for longer study duration of master students probable. The main reason is probably the activity in part-time or full-time jobs, where students are working additionally to the master lectures.

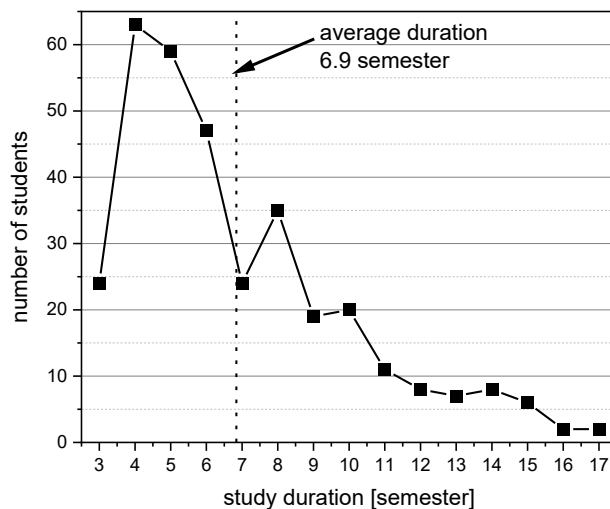

Fig. 7 Number of students who finished successfully the master course as function of their study duration. The average study duration is indicated with a dotted line.

Same as for the bachelor courses, also the average study duration for the master course increased with the years – with exception of the year 2019 (Figure 8). By view on this average value per year, it seems that a larger study duration is correlated with a better final mark of the master degree. This issue will be discussed in detail in sub-section 4.3.

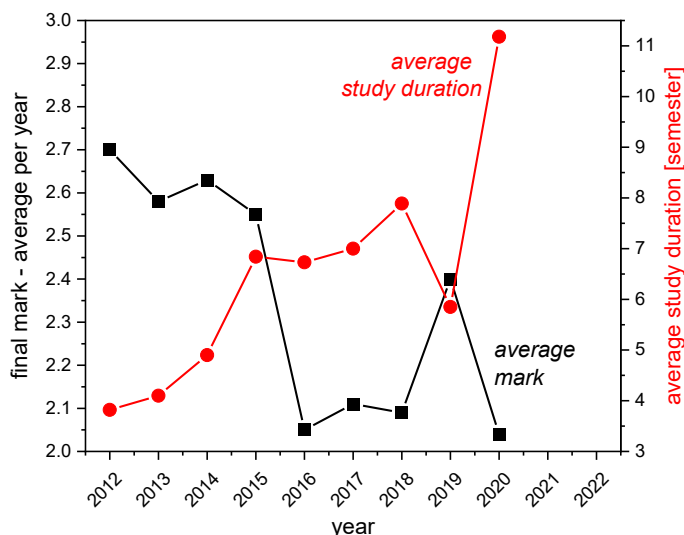

Fig. 8 Average value of master degree and average study duration for all students who finished the master degree in the same year.

4.2 Student performance

In the current study the student performance is measured by the final grade gained by each student for the complete study course after the degree is finished. Students leaving the faculty without a degree are not considered. As mark for the final degree a range from 1.0 (best) to 4.0 (worst) is possible. These marks are gained as average from all exams passed during the complete course, the final thesis and

final colloquium. Intermediate marks are gained as results of this average to 1/10, as e.g. 1.1; 1.2; 1.3 and following. Average values in between the 1/10 are counted to the better final degree, e.g. an average value of 1.099 is counted as final mark of 1.0. As described in sub-section 2, from this final mark the student performance index PI is calculated as reciprocal value. The PI is presented and discussed together with the gained final marks. To give a broader view on the data also the advanced performance index PID is calculated and discussed. In the following sub-sections, at first the bachelor course and then the master course is discussed. It should be remarked that in the data base of the master course in some older years, a few marks are lost and for this not considered here.

4.2.1 Bachelor course

The final marks gained by the bachelor students after the degree are illustrated in Figure 9 and compared with the student performance index PI. The number of students gained a certain mark is presented. The best mark gained is a 1.0 and the worst one a 3.6. Most students finished with a mark of 2.2 which is below the average of 2.36. An important grade is the mark 2.5, because with a mark of 2.5 or better it is allowed to join the master program of the faculty. More than 60% of bachelor students fulfill this criterium. However, there is still a significant number of former bachelor students who do not have the chance to join the master program. The graph with the PI exhibits the reciprocal distribution, while especially the few students with best final marks are presented with the highest PI values. The average value for the PI is 0.45 which corresponds to a final mark of 2.22.

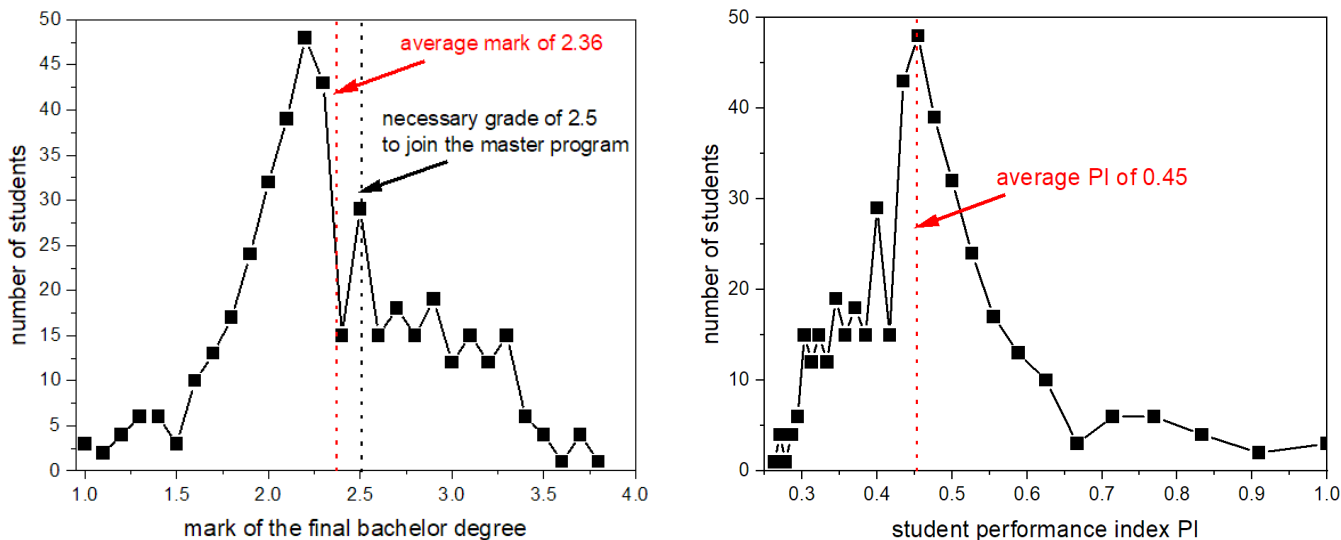

Fig. 9 Number of students who finished successfully the bachelor course as function of their final mark of bachelor degree (left) and student performance index PI (right). For comparison the average value is indicated with a dotted line.

4.2.2 Master course

The final marks of master students are presented in Figure 10 as a relation of number of students gained the same mark. A comparison to the related student performance index PI is also given in this figure. Similar to the bachelor course, most master students finish their degree with the mark 2.2. The average mark is slightly higher with 2.31. The marks recorded in Figure 10 are in the range of 1.1 to 3.5. For the PI the expected reciprocal distribution is visible with an average PI of 0.46 – corresponding to a mark of 2.17. By view on the performance index the master students are a little better compared to the bachelor students. However, this difference is not significantly higher.

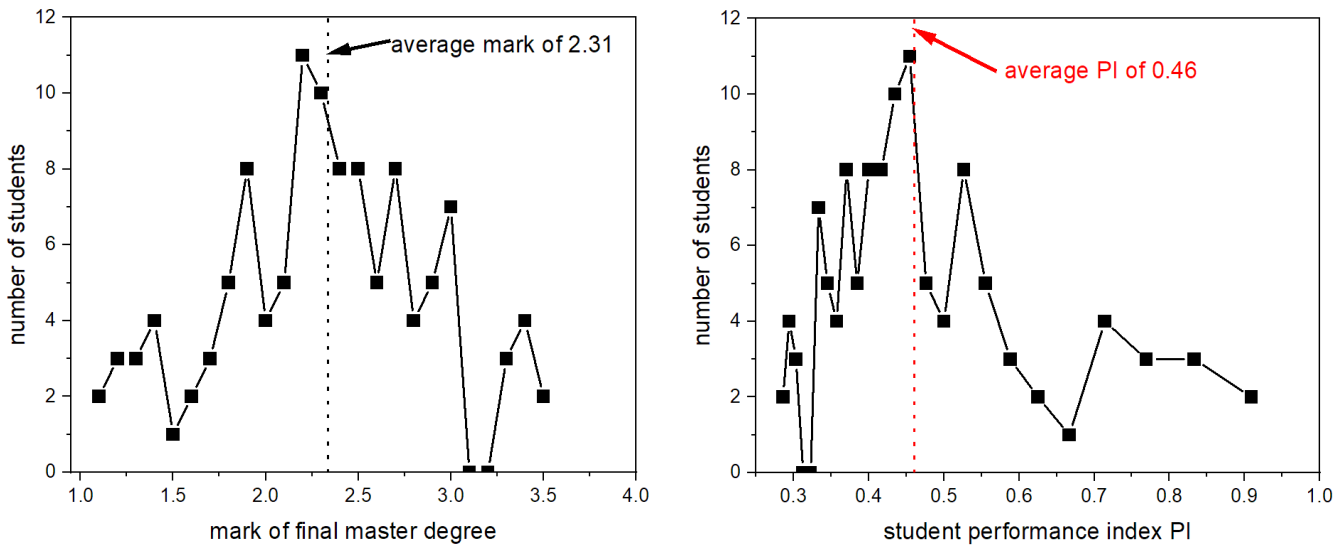

Fig. 10 Number of students who finished successfully the master course as function of their final mark of master degree (left) and student performance index PI (right). For comparison the average value is indicated with a dotted line.

4.3 Relation of study duration and performance

The main aim of investigation of the current study is to evaluate the relation of study duration and student performance. For this, the study duration is set in relation to the final mark of the students and the student performance index PI. To support a complete view on the data, two different types of data evaluation are performed and presented in the following sub-sections for bachelor and master course.

The first evaluation compares the values for all students with the same study duration and supports a linear regression on these data. The second evaluation uses the single values (individual study duration and related final mark, or student performance index PI) for this linear regression. Using the first type of evaluation with the average values, students with higher study duration have a stronger impact on the result of the linear regression. The data evaluation is done by linear regression using the software OriginPro 2020.

4.3.1 Bachelor course

The average values of final marks for all students and the PI with the same study duration is calculated and presented in Figure 11. Here, a clear trend to lower marks with increasing study duration is indicated. A performed linear regression exhibits a slope of 0.039. The student performance index PI decreased clearly with increasing study duration and the performed linear regression exhibits the negative slope of -0.005. However, it should be remarked that for the average values for study duration with 15 semester or more less than 5 students are counted for each average value. For those long durations, the marks of only few students determine the averages, so a certain fluctuation of results may occur. For the evaluation by linear regression, these few long-time students have a stronger influence in evaluation results compared to the majority of students finishing the study program in shorter time frame.

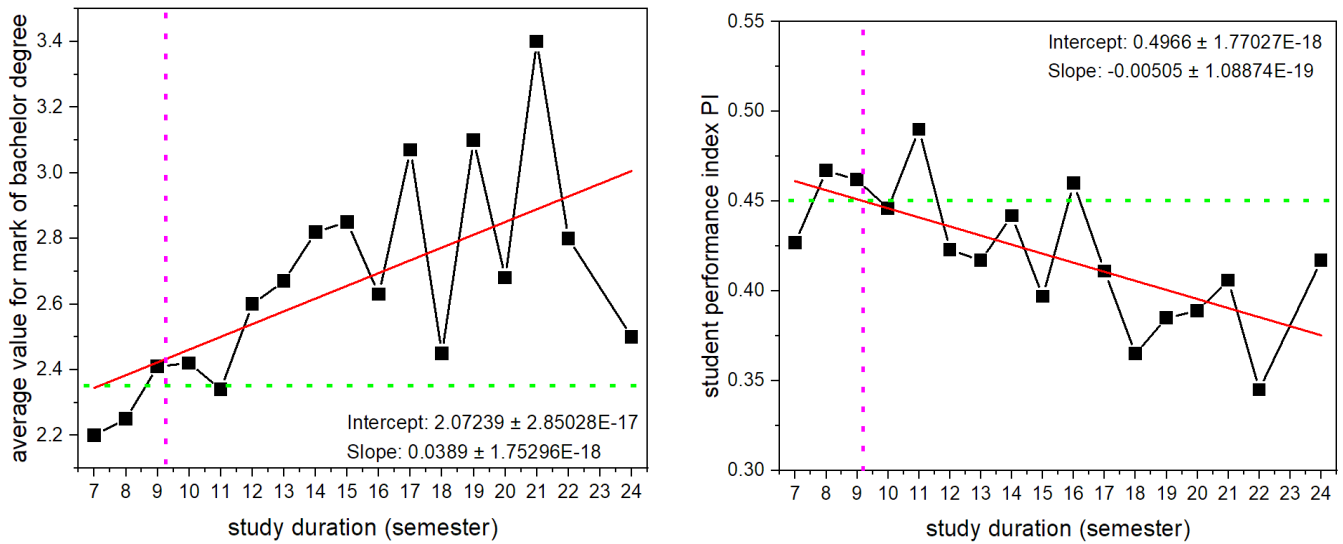

Fig. 11 Average values for final marks of bachelor degree (left) and student performance index PI (right) as function of the study duration. The black line is given as guide for the eye. The red line presents a linear regression. The green dotted line indicates the average mark and is given as orientation for the eye. The magenta dotted line indicates the average study duration or PI and is given as guide for the eye. The results from the linear regression are shown in the figure.

To evaluate the values for all students more equally, in the second evaluation the single values for all students (mark and study duration / PI and study duration) are considered and a linear regression is performed (Figure 12). By view on this Figure 12 it is clear that most numbers are in the range from 7 to 12 semester study duration. For longer study durations, the numbers are significantly lower. Nevertheless, even with this type of evaluation a significant decrease of final mark as function of study duration is recorded. The calculated slope as result of linear regression is with a value of 0.054 even significantly higher compared to the first evaluation shown in Figure 11. It is for this clear, a longer study duration is correlated with a lower student performance, as also seen by the decreased values for the PI with increasing study duration. However, there cannot be a statement if the longer study duration is the reason for lower performance or vice versa if it is the result of an in any case less performing student. Lower performing students could study in any case longer. However, a longer study duration could also lead to lower final marks, e.g. by time difference between visit of the lectures and the joined related exams.

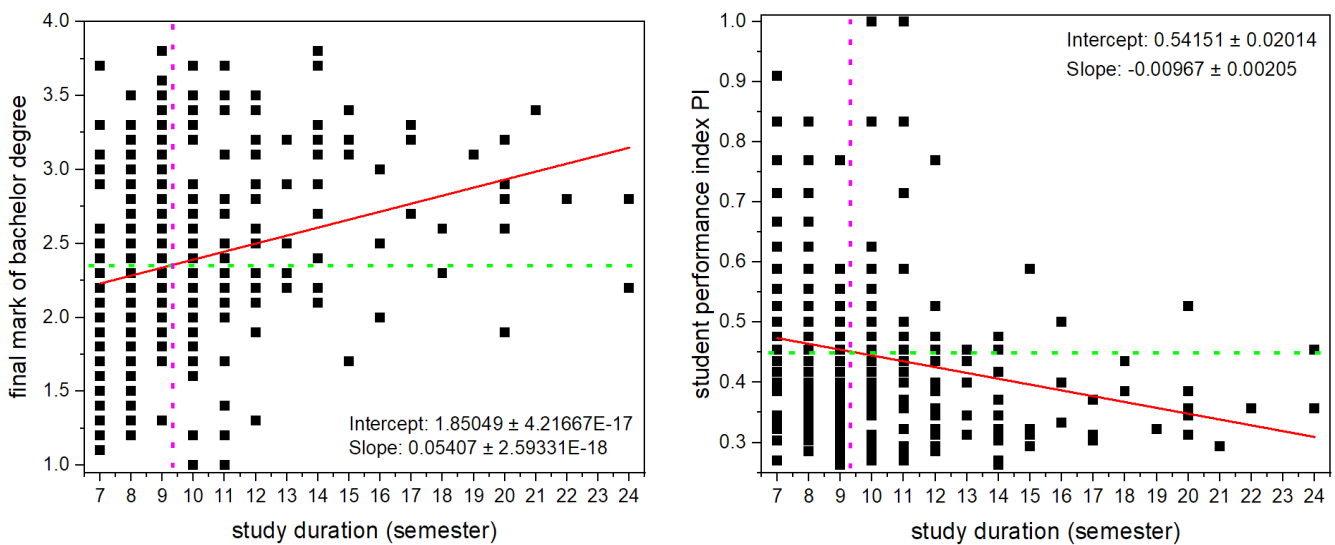

Fig. 12 Single values of each student for final marks of bachelor degree (left) and student performance index PI (right) as function of study duration. The red line presents a linear regression. The green dotted line indicates the average mark and is given as orientation for the eye. The magenta dotted line indicates the average study duration or PI and is given as guide for the eye. The results from the linear regression are shown in the figure.

To support a complete view on the evaluated data, also the advanced performance index PID is calculated and presented in Figure 13. Due to Eq. 2, of course a decrease of PID with increasing study duration is observed. Also, with PID a linear regression is done as data evaluation. However, compared to the evaluation of PI values, for the PID values the linear regression is probable not the best tool for data evaluation.

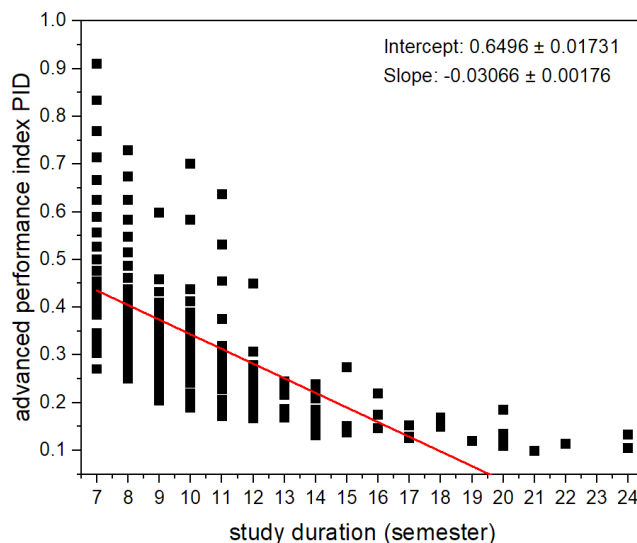

Fig. 13 Single values of each student for the advanced performance index PID as function of study duration. The red line presents a linear regression. The results from the linear regression are shown in the figure.

4.3.2 Master course

The average marks and the student performance index for master students finished with the same study duration are depicted in Figure 14. With these values, a data evaluation is done by linear regression. By this linear regression a correlation of longer study duration with lower student performance is shown. The calculated slope from this linear regression for the marks is with 0.053 in the range of the slopes determined also for the bachelor course. However, this result of linear regression is especially influenced by two values for long study duration of 14 and 17 semester. These values are only related to two master students and are for this in relation to the majority of the master students overestimated. For this reason, the second type of data evaluation using the single student values instead of average values leads probably to more reliable results.

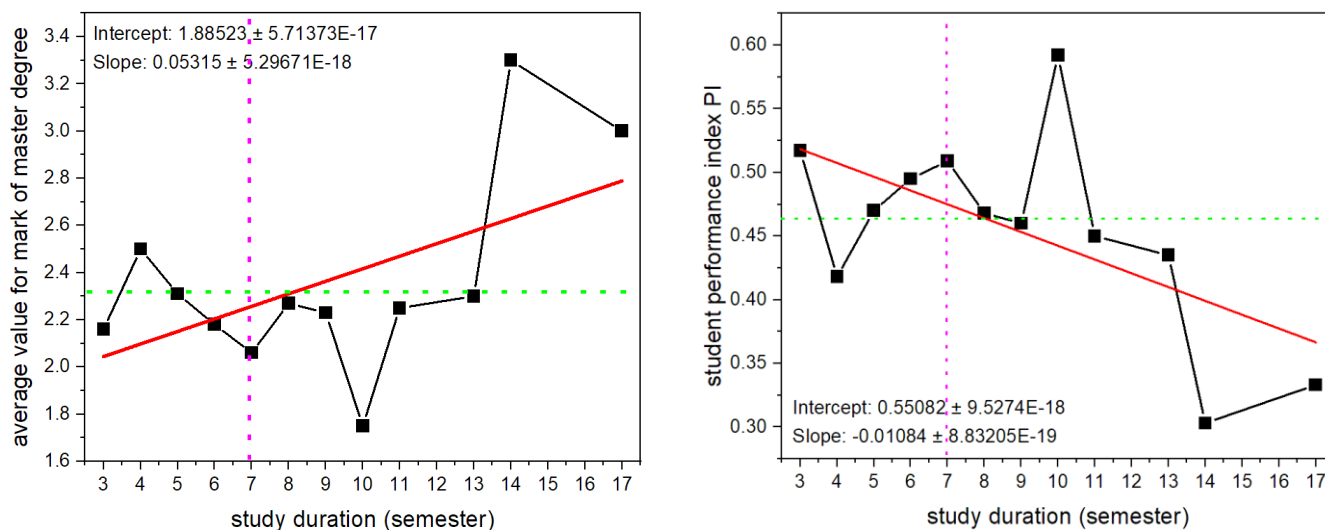

Fig. 14 Average values for final marks of master degree (left) and the student performance index PI (right) as function of study duration. The black line is a guide for the eye. The red line presents a linear regression. The green dotted line indicates the average mark as an orientation for the eye. The magenta dotted line indicates the average study duration or PI as a guide for the eye. The results from the linear regression are shown in the figure.

The individual values for the master students are recorded in Figure 15. The data evaluation by linear regression made on these data points leads to a nearly horizontal line indicating that there is no influence of the study duration on the student performance. By view on this data evaluation on the master course it can be concluded that there is no influence and correlation of study duration with the student performance. This result is significantly different to the also investigated bachelor course. A possible explanation could be the different reasons leading to a longer study duration. Many master students combine studying with part-time or even full-time jobs. By these job activities, the study duration is probably prolonged without an influence on the study performance.

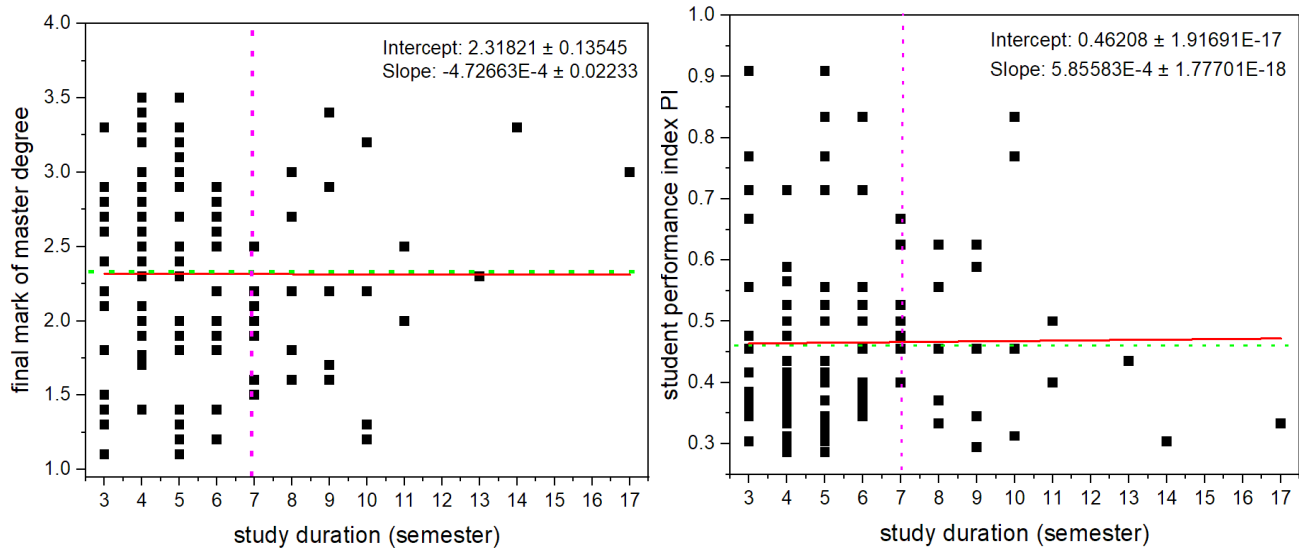

Fig. 15 Single values of each student for final marks of master degree (left) and student performance index PI (right) as function of study duration. The red line presents a linear regression. The green dotted line indicates the average mark and is given as orientation for the eye. The magenta dotted line indicates the average study duration or PI and is given as guide for the eye. The results from the linear regression are shown in the figure.

Also, for the master course as additional data evaluation the advanced performance index PID is calculated (Figure 16). By calculating the PID with Eq. 2, a longer study duration is considered as negative factor for the student performance. For this, in comparison to PI, the PID is decreasing with increasing study duration. This is also visible by comparing the linear regressions presented in Figure 15 and 16, even if the linear regression is not the best tool for data evaluation of PID values.

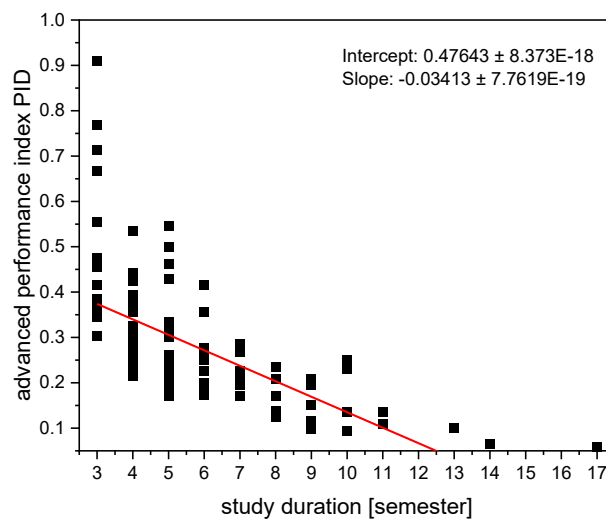

Fig. 16 Single values of each student for the advanced performance index PID as function of study duration. The red line presents a linear regression. The results from the linear regression are shown in the figure.

5 Conclusions

The student numbers and performance of a bachelor and a master course are evaluated over a long-term period of one decade. For the bachelor course a clear correlation of longer study duration with a lower academic performance is determined. However, it can not be finally concluded if the longer study duration is the result of or the reason for the lower academic performance. In contrast, for the investigated master course nearly no correlation of study duration and academic performance is observed. It can be estimated that the longer study durations of many master students are caused by parallel working in part-time or full-time jobs. For this, it could be concluded that especially for this type of master students a specially designed part-time master study program should be offered.

Acknowledgements

For support of data many thanks are owed to Christian Niemann and Gunhild Baumann.

Conflicts of Interest

The author declares no conflict of interest.

References

1. Asif, R.; Merceron, A.; Pathan, M.K. Predicting Student Academic Performance at Degree Level: A Case Study. *Intelligent Systems and Applications* **2015**, *1*, 49-61. DOI: 10.5815/ijisa.2015.01.05.
2. Razak, W.A.I.B.W.A.; Akmal, S.N.A.B.K.; Azizan, N.F.B.; Wani, S.; Hamal, A.Q.; Muhammad, A.H. Factors Affecting Students' Academic Performance. *International Journal on Perceptive and Cognitive Computing – IJPC* **2021**, *7*, 99-107.
3. Fajar, S.; Hussain, M.; Sarwar, H.; Afzal, M.; Gilani, S. A. Factors Affecting Academic Performance of Undergraduate Nursing Students. *Int. J. Soc. Sci. Management* **2019**, *6*, 7-16. DOI: 10.3126/ijssm.v6i1.22563.
4. Aleidi, S.M.; Elayah, E.; Zraiqat, D.; Abdallah, R., Al-Iede, M. Factors Affecting the Academic Performance of Medical, Dental, and Pharmacy Students in Jordan. *Jordan Journal of Pharmaceutical Sciences* **2020**, *13*, 169-183.
5. The effects of adolescent health-related behavior on academic performance: A systematic review of the longitudinal evidence. *Review of Educational Research* **2014**, *84*, 245-274. DOI: 10.3102/0034654313518441.
6. Darwish, E.; Alkhars, A. A.; Alkhars, F. M. Effects of marriage on the academic performance of undergraduate male students at the King Faisal University. *International Journal of Medicine in Developing Countries* **2021**, *5*, 1-5. DOI: 10.24911/IJMDC.51-1606463859.
7. Szu, E.; Nandagopal, K.; Shavelson, R.J.; Lopez, E.J.; Penn, J.H., Scharberg, M.; Hill, G.W. Understanding Academic Performance in Organic Chemistry. *J. Chem. Education* **2011**, *88*, 1238-1242. DOI: 10.1021/ed900067m.
8. Grethe, T.; Mahltig, B. Alternative Prüfungsformen im Sommersemester 2020. *Die Neue Hochschule DNH* **2020**, *06-2020*, 42-45.
9. Tesija, R. A.; Kruzicevic, S. M.; Banozic, A.; Esteban, C. D.; Sapunar, D.; Puljak, S. Impact of extended course duration and stricter study organization on attrition and academic performance of medical students. *Croat. Med. J.* **2013**, *54*, 192-197. DOI: 10.3325/cmj.2013.54.192.
10. Mahltig, B. Conversion of a conventional to a digital lecture under the conditions of Covid19 – an example from a bachelor lecture on finishing, dyeing & printing. *Communications in Development and Assembling of Textile Products – CDATP* **2021**, *2*, 173-186. DOI: 10.25367/cdatp.2021.2.p173-186.